



# Technical Information Private Driveways

# BP-17

Department of Building and Planning

Section 3.6.050(a)2(ii), Fire Apparatus Access, of Title 3 of the Spokane County Code defines private driveways as access roads that serve no more than three (3) parcels. They must be constructed in substantial conformance with the following standards developed and recommended by the Spokane County Fire Prevention Committee. Driveway approaches are subject to conformance with the Spokane County Road Standards and requirements are outlined in Brochure E-3 *Rural Residential Approaches* and E-4 *Urban Residential Approaches*.

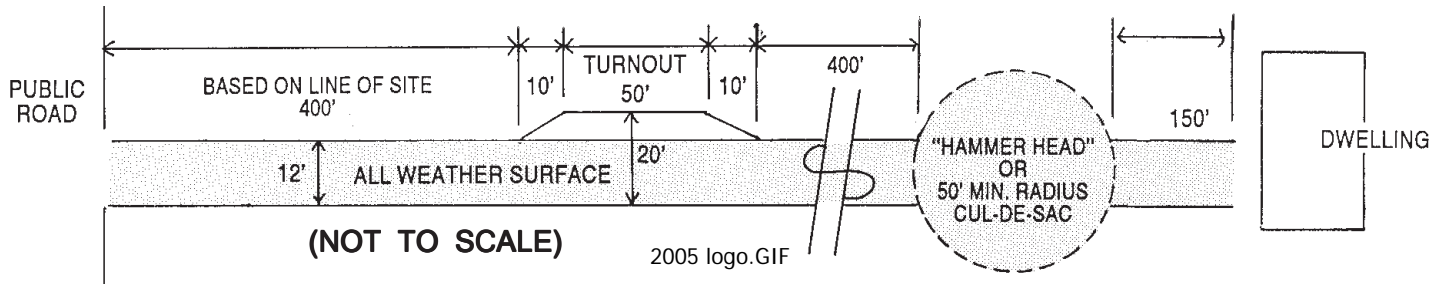

- **Max. Grade:** 12% - 14% maximum (outside right-of-way) 2-8%; within right-of-way – contact the Spokane County Division of Engineering and Roads.
- **Width:** 12' clear travelway with all-weather surface.
- **Turnouts:** One approximately every 400 feet. All-weather surface 20' in total width for 50' in length.
- **Turnaround:** Required for driveways over 150' in length. "Hammerhead" or 50' minimum radius cul-de-sac needs to be within 150' of dwelling
- **Permits:** Approach permits are required from the Division of Engineering and Roads to connect to any county public road. Private driveways constructed prior to obtaining building permits may require a grading permit.
- **Inspections:** Installation inspection and acceptance of the driveway is required prior to dwelling occupancy (i.e., road surfacing, width, vertical clearance and drainage).
- **Curves:** No curve radius shall be less than 100' measured from the road centerline unless approved by the local fire district and the Department of Building and Planning.
- **Drainage:** Corrugated metal pipe (CMP) or approved alternate: Driveway cross pipes at approaches to the Fire Apparatus Access Roads, public or private, shall be a minimum of 12" in diameter.

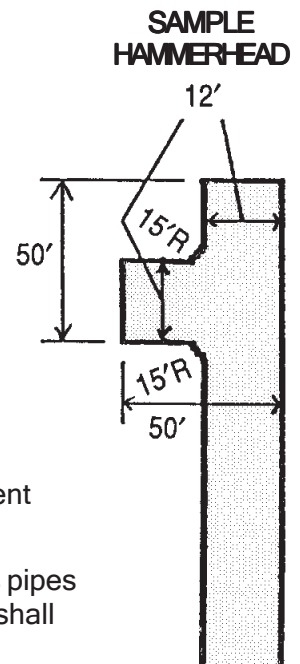

- **Maintenance:** A recorded road maintenance agreement with financial provisions is recommended. Please note that Spokane County is not responsible for building, improving, maintaining, surveying, constructing, repairing, providing drainage or snow removal on any private driveway.

### **Other brochures that may be helpful**

BP-19 *Erosion & Sediment Control*

BP-19a *Erosion & Sediment Control Techniques*

BP-46 *Grading and Parking Lot Permits*

BP-46a *Typical Grading Permits*

### **For more information or an appointment contact:**

Spokane County Public Works

Department of Building and Planning

1026 W. Broadway, Spokane, WA 99260-0050

(509) 477-3675 [bp@spokanecounty.org](mailto:bp@spokanecounty.org)

<http://www.spokanecounty.org/bp>

Please note that while every effort is made to assure the accuracy of the information contained in this brochure it is not warranted for accuracy. This document is not intended to address all aspects or regulatory requirements for a project and should serve as a starting point for your investigation. For detailed information on a particular project, permit, or code requirement refer directly to applicable file and/or code/regulatory documents or contact the appropriate division or staff.